

*OverheadCraneKit.com*

# QUOTE PROPOSAL

---



**Presented by:**

*OverheadCraneKit.com*

800-509-6131

[info@OverheadCraneKit.com](mailto:info@OverheadCraneKit.com)

**Date:**

04/04/2008

**Quote ID:**

E1000

An authorized distributor of:

**GORBEL**  
A C L A S S A B O V E

**OverheadCraneKit.com**  
**(800) 509-6131**

**Customer Quotation**

**Attn: Customer**

Date	Quotation Number
4/4/2008	E1000

Name / Address
OverheadCraneKit.com Customer

Ship To
Customer Location

Invoice Terms	Delivery	Quote Valid Until	Quoted By
TBD	5-10 Days	4/30/2008	TRS

Qty	Item	Description	Each	Total
1.00	New Equipment	Gorbel 1 Ton Freestanding Worstation Crane; 20ft bridge x 40.5ft runway length- see attached specifications  Taxes and freight charges are not included.	9,915.00	9,915.00T

Taxes and freight charges are not included	<b>Subtotal</b>	\$9,915.00
<b>OverheadCraneKit.com provides Quality Products, Competitive Pricing, Knowledgeable Support Staff, and Quick Deliveries. Call us at (800) 509-6131</b>	<b>Sales Tax (0.0%)</b>	\$0.00
	<b>Total</b>	\$9,915.00

**CONFIDENTIAL**

SUPPORT ASSEMBLIES ARE DESIGNED TO AISC SPECIFICATIONS. IF NO MOVEMENT OF SUPPORT ASSEMBLIES IS REQUIRED, THEN BRACING TO BUILDING STEEL IS RECOMMENDED (NOT INCLUDED).

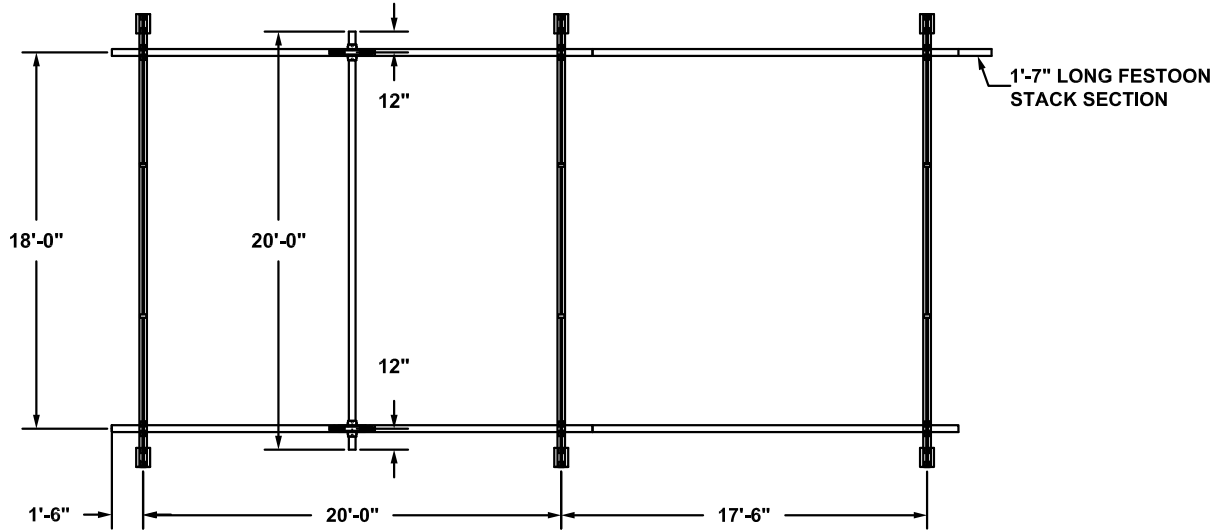

BRIDGE TROLLEY TRAVEL IS 17'-3 9/16".  
 ENDTRUCK TRAVEL IS 37'-9 1/2".

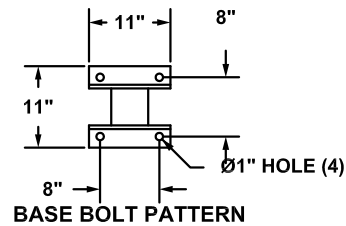
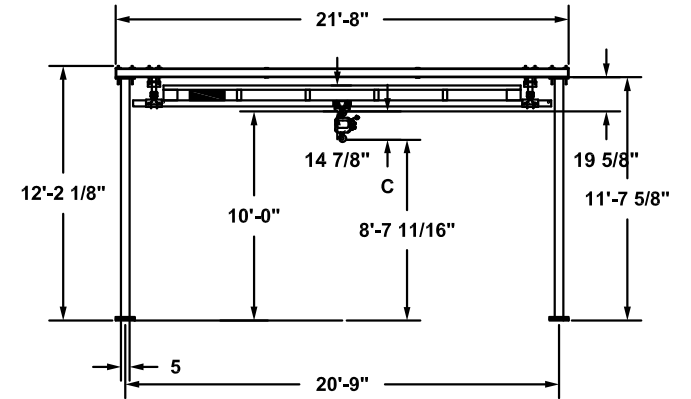
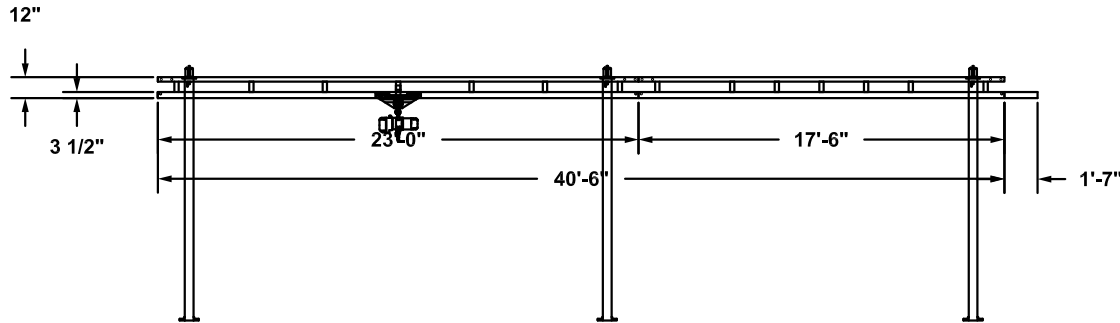

HANGERS ARE ON 20' CENTERS MAXIMUM WITH A 48" CANTILEVER ON EACH END MAXIMUM. HANGERS MUST BE WITHIN 48" OF SPLICE JOINT

DO NOT SCALE FROM DRAWING. DIMENSIONS ARE STEEL TO STEEL AND MAY VARY. HANGER POSITION TOLERANCE = ±2 1/2"

CRANE INFORMATION		<b>OverheadCraneKit.com</b> <b>(800) 509-6131</b>	
CAPACITY: 2000LBS/BR			
BRIDGE OAL: 20'-0"		GENERAL ARRANGEMENT	
BRIDGE SERIES: 2000			
RUNWAY OAL: 40'-6"		BY: TRS	
RUNWAY SERIES: 2000		DATE: APR 2, 2008	
TOLERANCE: ±1/8		CO: OHCK	
QUANTITY: 1		Gorbel FS Crane	

**WORKSTATION BRIDGE CRANE SPECIFICATION**

Line #1

Model Number:	GLCS-FS-2000-20-40.5-10	Quantity:	1
		Ship Date Range:	5-10 working days from order
		Total Weight:	4284 lbs
Crane Warranty:	5 years		

**Bridges:**

**Bridge 1 Design**

Capacity:	2000 lbs	Length:	20 ft	Overall Width:	21.667 ft
Quantity:	1	Material:	Steel	Series:	2000
Color:	Yellow	Hoist Trolleys:	1 per bridge		

**Runways**

Length:	40.5 ft	Cantilever:	1.5 ft	Color:	Blue
Material:	Steel	Series:	2000	Style:	GLCS
Overall Length:	42.0833 ft (includes stack section length)				
Automotive Options:	None				
Runway Sections:	23 ft - 17.5 ft				
Support Centers:	20 ft - 17.5 ft				

**Supports**

Number of Supports:	3	Overall Height:	12.178 ft	Sway Brace Fittings:	0
Anchor Bolts:	None	Anchor Bolt Load:	1926.072 lbs.		
Trolley Saddle:	10 ft				

**Festooning**

Runway Carrier:	6-Gliders	Festoon Clamps:	Runway: 1, Bridge: 1	Festoon Stack Up:	1 @ 19 inches each
Conductor Type:	Flat Cable (4-conductor #14 AWG) 1 pcs @ 70 ft each				
Bridge Carrier:	Bridge 1: 6-Gliders				

# 5 Year Warranty

*Gorbel's 5 year warranty is the best in the industry.*

**Products Included in 5 Year Warranty:**

- Manual Work Station Cranes (Free Standing and Ceiling Mounted Bridge Cranes, Monorails)
- Manual Jibs (Work Station Jibs, Articulating Jibs, I-beam Jibs)

**What is Covered for 5 Years:**

- Defects in material and workmanship
- Wearable parts (trolley and end truck wheels only)

**Details:**

It is agreed that the equipment purchased hereunder is subject to the following LIMITED warranty and no other. Gorbel Incorporated ("Gorbel"), warrants the manual push-pull Work Station Cranes and Jib Crane products to be free from defects in material or workmanship for a period of five years or 10,000 hours use from date of shipment. Gorbel warrants the Motorized Work Station Cranes and Jib Crane products to be free from defects in material or workmanship for a period of two years or 4,000 hours use from the date of shipment. This warranty shall not cover failure or defective operation caused by operation in excess of recommended capacities, misuses, negligence or accident, and alteration or repair not authorized by Gorbel. OTHER THAN AS SET FORTH HEREIN, NO OTHER EXPRESS WARRANTIES, AND NO IMPLIED WARRANTIES, ORAL OR WRITTEN, INCLUDING BUT NOT LIMITED TO THE WARRANTIES OF MERCHANTABILITY OR FITNESS FOR A PARTICULAR PURPOSE, ARE MADE BY GORBEL WITH RESPECT TO ITS PRODUCTS AND ALL SUCH WARRANTIES ARE HEREBY SPECIFICALLY DISCLAIMED. GORBEL SHALL NOT BE LIABLE UNDER ANY CIRCUMSTANCES FOR ANY INCIDENTAL, SPECIAL AND/OR CONSEQUENTIAL DAMAGES WHATSOEVER, WHETHER OR NOT FORESEEABLE, INCLUDING BUT NOT LIMITED TO DAMAGES FOR LOST PROFITS AND ALL SUCH INCIDENTAL, SPECIAL AND/OR CONSEQUENTIAL DAMAGES ARE HEREBY ALSO SPECIFICALLY DISCLAIMED. Gorbel's obligation and Purchaser's or end user's sole remedy under this warranty is limited to the replacement or repair of Gorbel's products at the factory, or at the discretion of Gorbel, at a location designated by Gorbel. Purchaser or end user shall be solely responsible for all freight and transportation costs incurred in connection with any warranty work provided by Gorbel hereunder. Gorbel will not be liable for any loss, injury or damage to persons or property, nor for damages of any kind resulting from failure or defective operation of any materials or equipment furnished hereunder. Components and accessories not manufactured by Gorbel are not included in this warranty. Purchaser's or end user's remedy for components and accessories not manufactured by Gorbel is limited to and determined by the terms and conditions of the warranty provided by the respective manufacturers of such components and accessories.



# IF WE'RE LATE, WE PAY THE FREIGHT

Explanation, Terms and Conditions

## On Time...or It's Out of *Our* Pocket

At Gorbel, we are committed to providing our customers with high quality products in a timely manner. We know that delivery can be the most critical component of your material handling system. We are so confident in our ability to get your product to you when you need it that we put our money where our mouth is.

Our "If We're Late, We Pay the Freight" program was created with customers like you in mind. Simply put, if you have requested this program\* and we don't have your order ready to ship on or before the promised date, we will credit an amount equivalent to the going rate for the freight.

## How Do I Know What "Late" Is?

The program includes both Quick Ship and special orders. Just check with your dealer for the scheduled ship date - dealers are notified of this within 1-2 business days of Gorbel receiving the order. If we don't have your order ready to ship on or before our promised date, we will credit your dealer's account at time of shipment an amount equivalent to the going rate for the freight.

## How Can Gorbel Afford This?

Simple - we don't intend to be late in the first place. Too good to be true? Not a chance:

- We have averaged 99.4% on time shipments for the past decade.
- Most Gorbel cranes are shipped in 5 working days or less

## Terms & Conditions

- Program applies to North American shipments only
- All Work Station Cranes, Jib Cranes, Cleveland Tramrail™, G-Force™ and Easy Arm™
- Program does not apply to expedited shipments (i.e. requests for shipments faster than Gorbel's original acknowledged date)
- This program guarantees we'll have your order **ready to ship** on or before the date promised - Gorbel is not responsible for carrier delays.
- We are not responsible for delays caused by acts of God or carrier strikes.

## Questions?

Please contact your Gorbel dealer [OverheadCraneKit.com](http://OverheadCraneKit.com) at (800) 509-6131.

\* You must specifically request this program at the time of your order. If delivery is critical to your order, tell your dealer that you'd like that order to qualify for our "If We're Late, We Pay Freight" program. The delivery date will be negotiated once Gorbel receives the Purchase Order from the dealer.

