

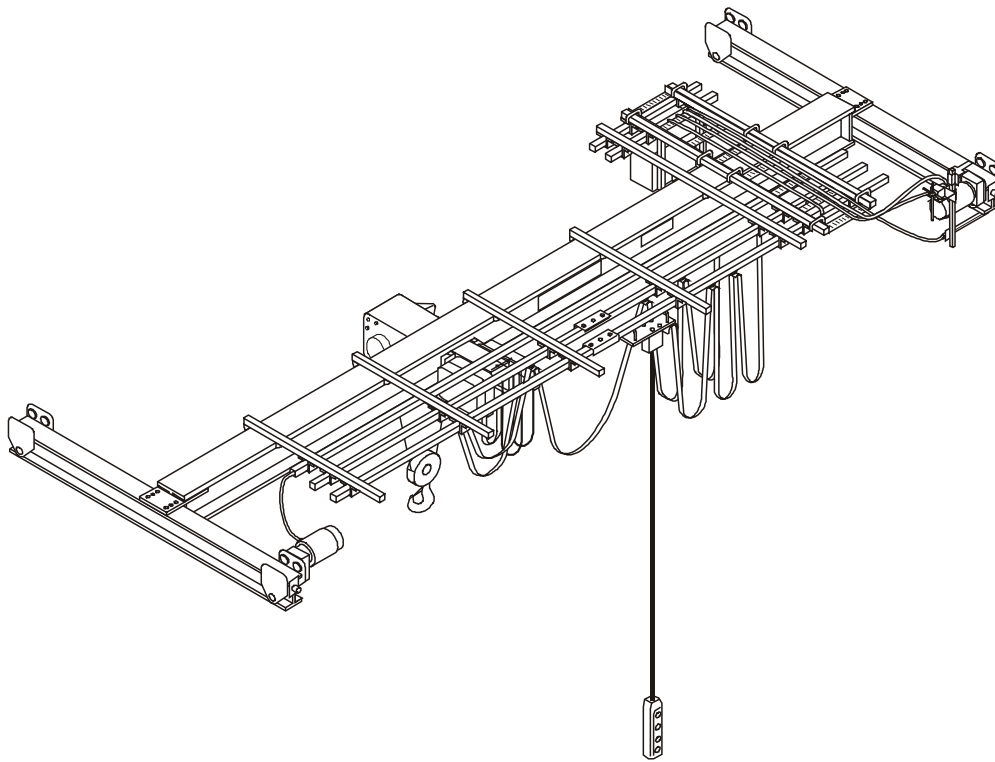

QX Modular Crane Assembly Instructions



Single Girder, Under Running Crane
1 Hoist per Bridge



R&M Materials Handling, Inc
Springfield, Ohio USA
☎: 800 955-9967
web: www.rmhoist.com

Spacemaster SX Hoist
QX Crane Assembly Instructions
Single Girder Under Running
Revision 2

The QX Modular Crane Assembly Instructions have been prepared to acquaint you with the procedures necessary for assembling of the QX Modular Crane that you will install.

Installation, Operation, and Maintenance Instructions for the hoist and bridge drives are also provided.

Proper installation is important to the performance of this equipment. Careful study of and adherence to the instructions will help ensure safe, dependable operation. It is also recommended that you keep the manuals for the equipment readily accessible to operators as well as maintenance and safety personnel.

Information in this manual is subject to change without notice.

R&M Materials Handling, Inc
4501 Gateway Boulevard
Springfield, Ohio USA
Phone: 800 955-9967
Fax: 800 955-5162

Visit us on the web: www.rmhoist.com



CONTENTS

GENERAL 4

POWER CONNECTIONS..... 4

BRIDGE BEAM 5

BRIDGE TRAVEL LIMIT SWITCH..... 5

BRIDGE BEAM CONNECTION 6

MAIN CRANE COMPONENTS..... 8

BRIDGE DRIVE ASSEMBLY – UT16 END TRUCK 10

BRIDGE DRIVE ASSEMBLY - UC END TRUCK 12

CRANE POWER TOW ARM ASSEMBLY 14

HOIST TOW ARM ASSEMBLY 16

HOIST TOW ARM ASSEMBLY 17

HOIST TOW ARM ASSEMBLY 18

BUMPER STOP ASSEMBLY ≤ 3 TON [3200 KG] 19

BUMPER STOP ASSEMBLY > 3 TON [3200 KG] 20

BRIDGE PANEL ASSEMBLY 22

FESTOON ASSEMBLY 24

PLUG IDENTIFICATION AND LAYOUT 26



General

A QX Modular Crane Package includes:

- Spacemaster SX hoist,
- Bridge end trucks including beam connection plates (except for UT type under running trucks),
- Bridge drives,
- Bridge panel that includes a thru-door mainline disconnect, mainline fuses, mainline contactor and a control transformer (for both hoist & crane),
- Complete festoon package featuring plugs for quick connections,
- Festoon tow arm for hoist,
- Bridge tow arm for main power,
- Bridge travel limit switch,
- Sliding pendant on its own festoon rail,
- Suggested beam for bridge girder for capacity and span that the user specifies (beam furnished by others),
- Crane assembly instructions,
- Installation, Operation & Maintenance manuals for components such as the hoist and the bridge drives

Prior to permanent installation, the equipment shall be checked by qualified personnel for damage during shipment or handling at the job site. Particular attention shall be taken to make sure that the hoist wire rope and the limit switch mechanism have not been damaged by improper use of forklifts or sling chains.

IMPORTANT

Hoists/cranes are designed for lifting and transporting of materials only. Under no conditions or circumstances, either during initial installation or in regular use, are the hoists/cranes to be used for lifting or transporting of personnel.

Only trained and competent personnel may handle the hoist/crane. When using slings, chains or hook to handle the hoist/crane, use the designated lifting points or lugs. Never suspend the hoist by the drum, counterweight, control enclosure or motors.

Before installing trolley mounted hoists, rail stops must be installed for all trolleys mounted on open-end beams. These stops must be positioned such that only the trolley frames absorb any impact forces. Do not allow the trolley wheels to impact rail stops.

Power Connections

According to CMAA Specification #74, a minimum of two collectors for each runway conductor shall be used with inverter use.

In addition, the use of a ground shall be utilized, either through the frame ground or a conductor ground.

Proper grounding is important with inverter use. A poor ground could cause damage to the inverter or could create a shock hazard to personnel.

Proper Crane Motion

Crane traveling motions are set for when the operator is standing on the push button side of the bridge, facing the load. If the direction of the bridge drive travel does not correctly correspond with respect to the bridge button being depressed, check the following possibilities:

1. If all motions are opposite with respect to the pushbutton markings, swap two of the main power leads at the bridge panel (for hoist and trolley motion checks see start-up section in the hoist's Installation, Operation and Maintenance manual).
2. Then, if necessary, change the bridge travel direction by switching plugs X-211 and X-221 at the bridge panel.



Bridge Beam

QuoteMaster™ generates a suggested beam size for the bridge girder for the crane application. The shape of the suggested beam is normally a Wide Flange. It is the responsibility of the user to furnish the bridge beam.

The adequacy of the suggested beam or of a substitute bridge beam for the crane application is the responsibility of the user and should be determined by qualified personnel.

The hoist trolley is pre-adjusted for either the suggested bridge beam or for a predetermined flange width. After installing the hoist on the beam the user shall make sure the trolley is properly adjusted. Trolley installation instructions are described in the hoist's Installation, Operation and Maintenance Instructions.

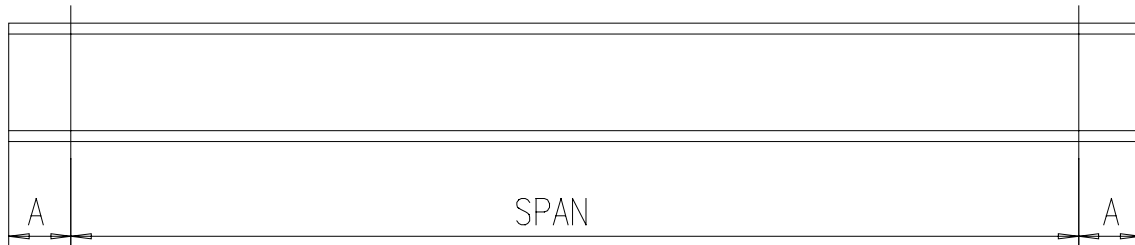

The bridge beam length for UC or UT16 end truck may be estimated by using the formula of $SPAN + 2A$. SPAN is horizontal distance center-to-center of runway rails and dimension "A" is the length from crane wheel center to the outside edge of the beam connection plate or bridge beam.

End Truck Type	Runway Flange Range	Connection Plate	Dimension "A"
UC		C10(A)	10 3/4" [273mm]
UC		C10(B)	13 3/8" [340mm]
UT16	3.54 - 7.87" [90-200mm]	---	20" [508mm]
UT16	7.91 - 11.81" [201- 300mm]	---	21 1/2" [546mm]

Bridge Travel Limit Switch

The bridge travel limit switch for QL Modular Crane Packages is supplied as standard. Unless otherwise specified at order inquiry, this limit switch will operate as a slow-down limit.

The function of the bridge travel limit as a slow-down limit is to deactivate bridge fast speed and to changeover to slow speed when the bridge travel limit switch is tripped as the crane approaches either end of the runway. Bridge fast speed is deactivated until the bridge travel limit switch is reset back to its neutral position. Reversing the direction of the crane so that the limit switch turnstile strikes again the trip device resets the limit switch. Once the switch is reset back to its neutral position, bridge fast speed becomes available again.

The bridge travel limit switch is a maintained type and it is equipped with a turnstile. The trip device must be located on the runway beam positioned to trip the turnstile.

The user is responsible for furnishing and mounting the trip device, made from either rod or bar stock.

The bridge panel is Ready-to-Run after the user connects all the applicable plugs including the limit switch.

Not Installing Bridge Travel Limit Switch

If the user decides not to install the supplied bridge travel limit switch, then wire jumpers must be added to the bridge controls to accommodate for the missing limit switch connection. Adding these jumpers



bypasses the limit switch circuit and brings online bridge fast speed that otherwise is disabled because the limit switch was not installed.

Refer to the wiring diagrams, in particular the bridge panel wiring diagram, that are included with your manuals before making any jumper connections.

Install a jumper from terminal X1: 50 to limit switch input(s) on the inverter in the bridge panel. Depending on the inverter type, there could be more than one limit switch input on the inverter. Each one of these limit switch connections on the inverter must be jumper connected. For example, if multiple switch inputs on the inverter are being used, then add a jumper from terminal X1: 50 to Input "A", then from Input "A" to Input "B" and so on.

Bridge Beam Connection

The adequacy of the suggested bridge beam connection for the crane application is the responsibility of the user and should be determined by qualified personnel.

UC-STD-C10 Bridge Beam Connection

The total length of the C10 connection plates is $2 \times A$. Dimension A is in the table under the Bridge Beam section.

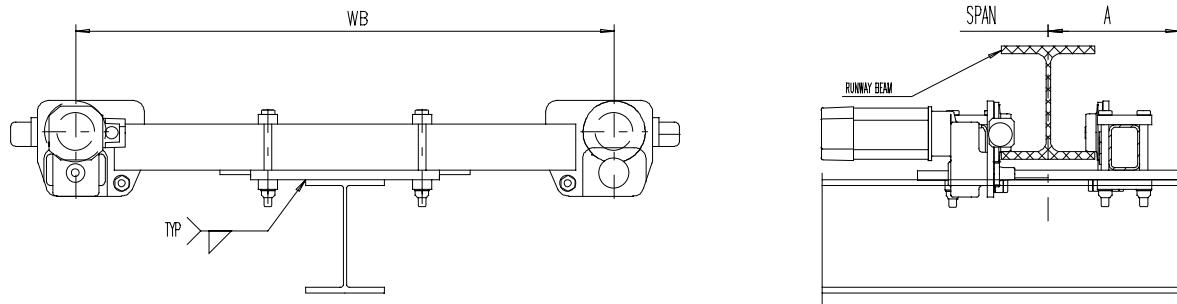

The connection plates C10(A) and C10(B) will not accept a bridge beam flange width that is greater than 13 inches (330 mm).

The bridge beam may be coped before it is connected to the C10 connection plates as an acceptable alternative. It is the responsibility of the user to determine the adequacy of the connection.



UT16-STD Bridge Beam Connection

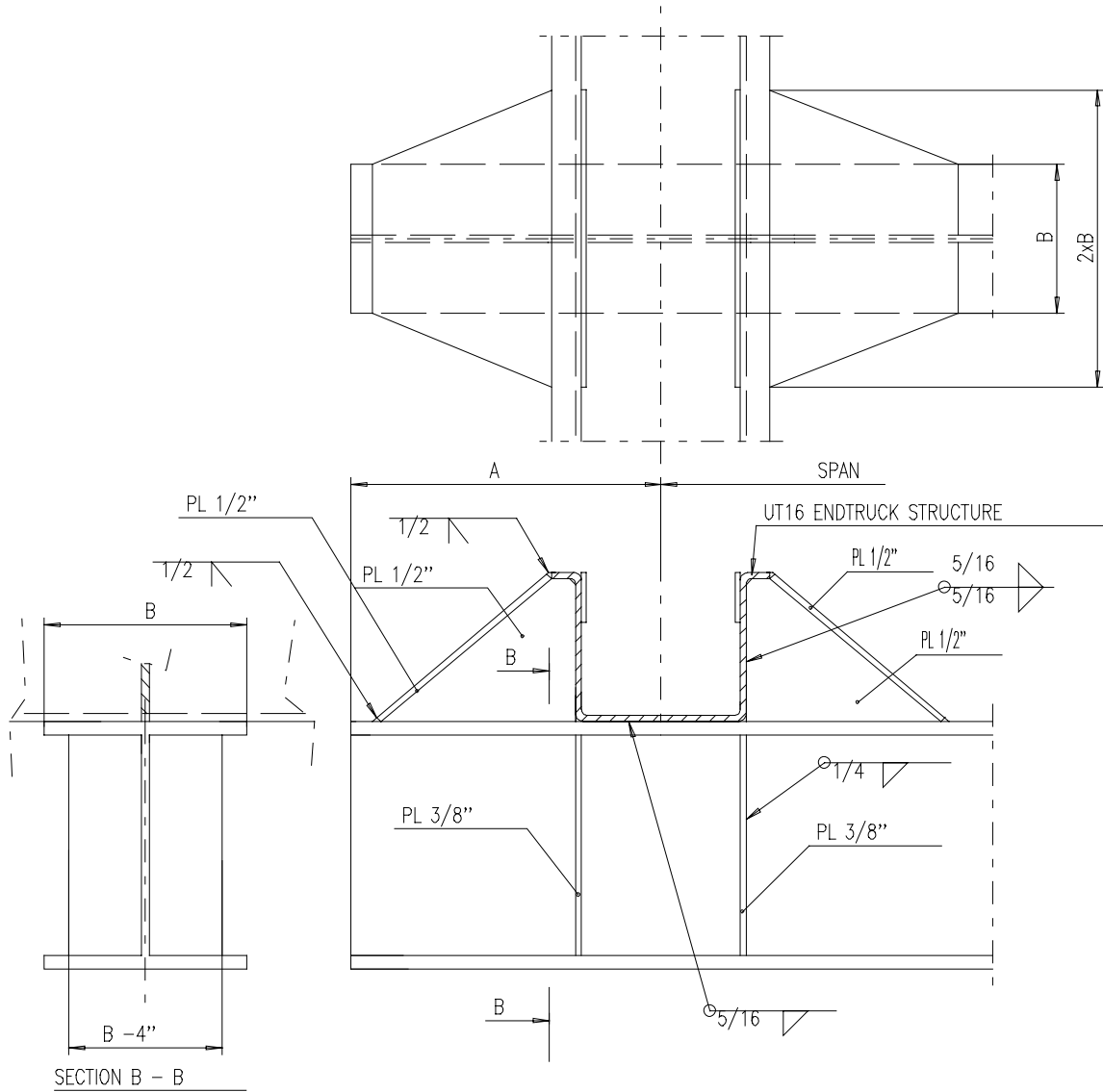



Main Crane Components

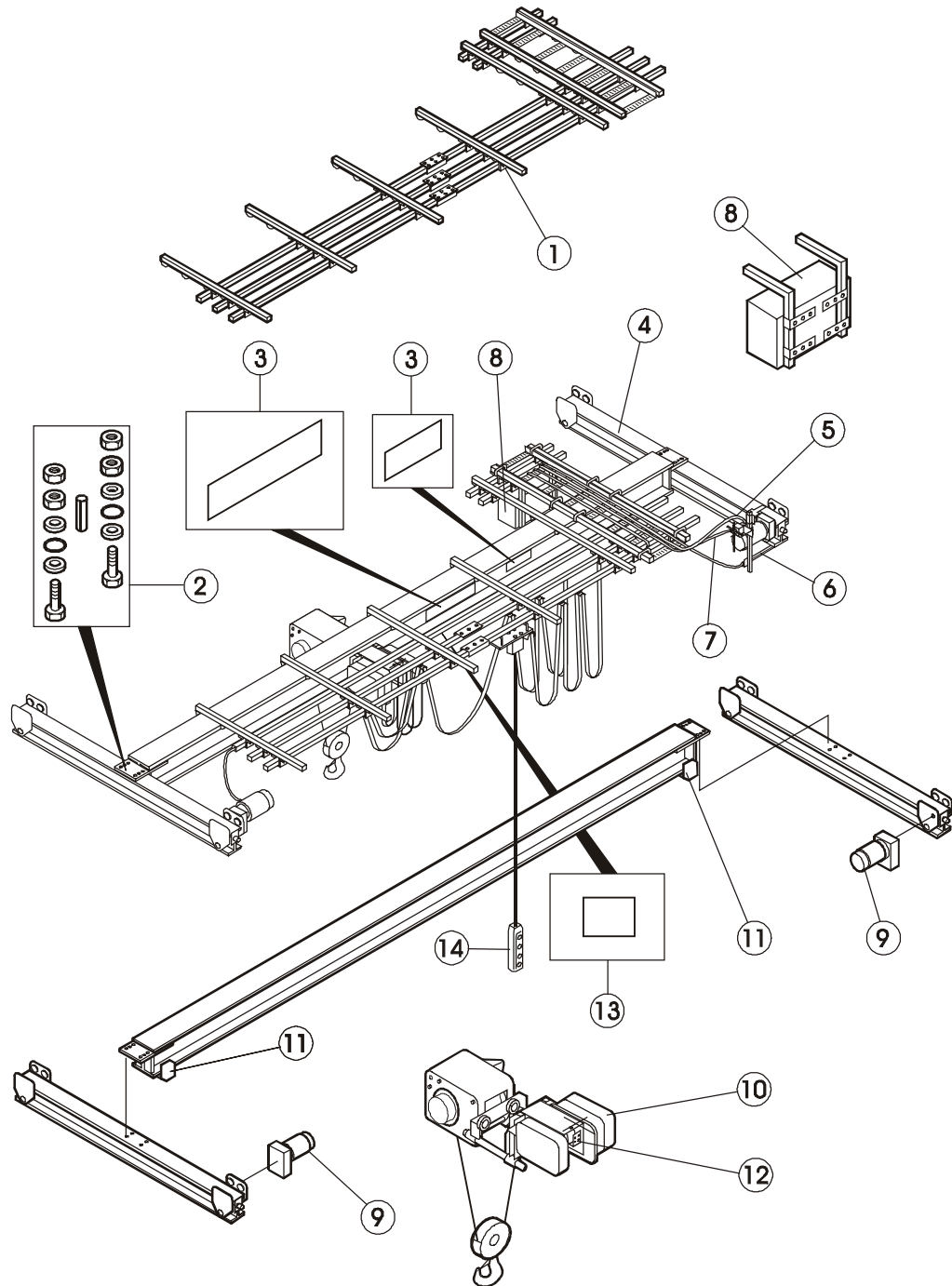

AIMCEN51A



Main Crane Components

Parts List

- 1 Festoon Package
- 2 End truck fasteners
- 3 Capacity + logo stickers
- 4 End truck
- 5 Bridge motor electrical cable
- 6 Crane tow arm assembly
- 7 Limit switch for crane traveling
- 8 Bridge panel
- 9 Bridge drives
- 10 Hoist
- 11 Bumper end stop
- 12 Hoist tow arm
- 13 Direction symbols
- 14 Push button pendant station



Bridge Drive Assembly – UT16 End Truck

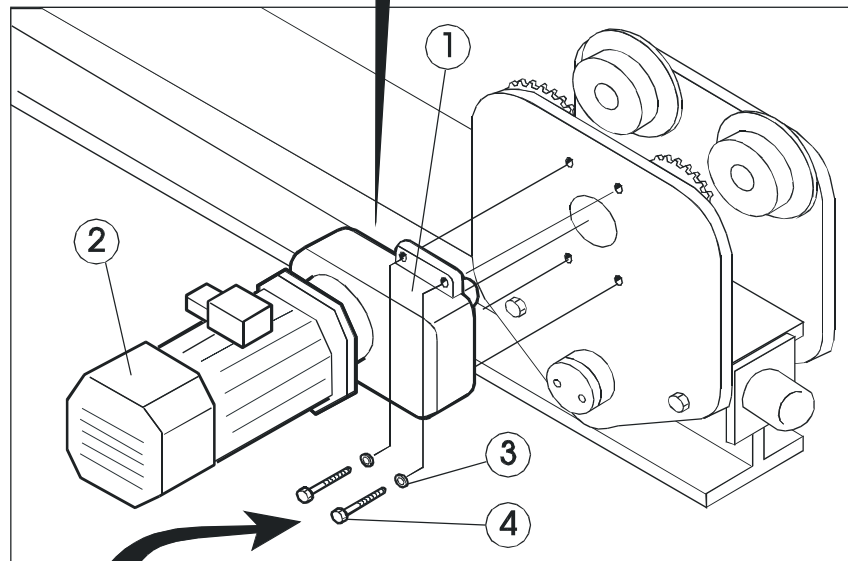
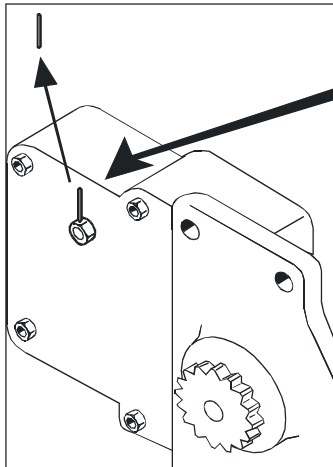

AIMCEN43A



Bridge Drive Assembly – UT End Truck

Parts List

- 1 Bridge drive
- 2 Motor
- 3 Bolt
- 4 Washer



Explanations for NOTES in the drawing

Clean the spline and mounting flanges of dirt and rust protection wax and grease the spline lightly before assembly. You can use a plastic hammer to slide drive in. Do not use a metal or lead hammer.

M10 Tightening torque 30 ft-lb (40 Nm)

Remove the protection pin from the breather plug on drives.



Bridge Drive Assembly - UC End Truck

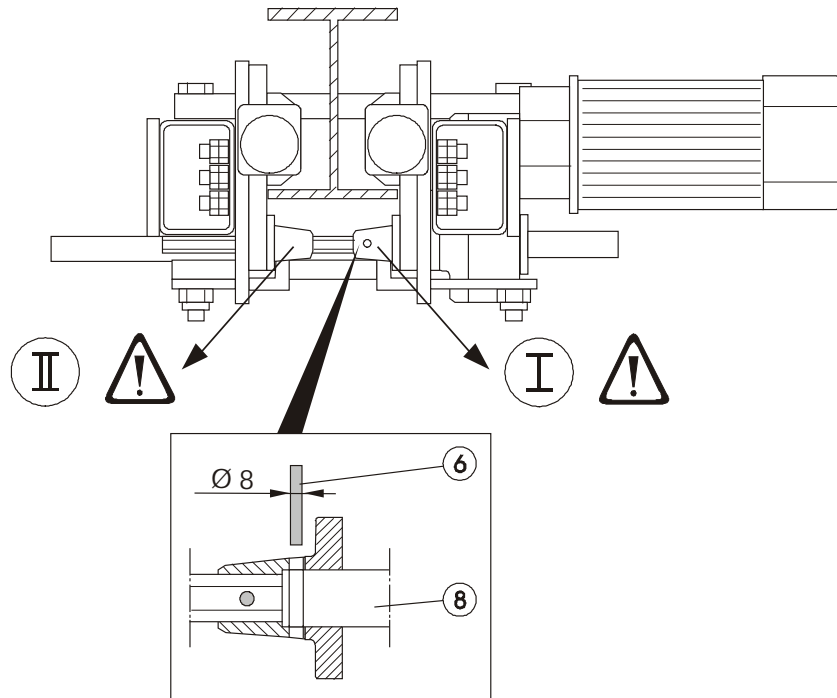
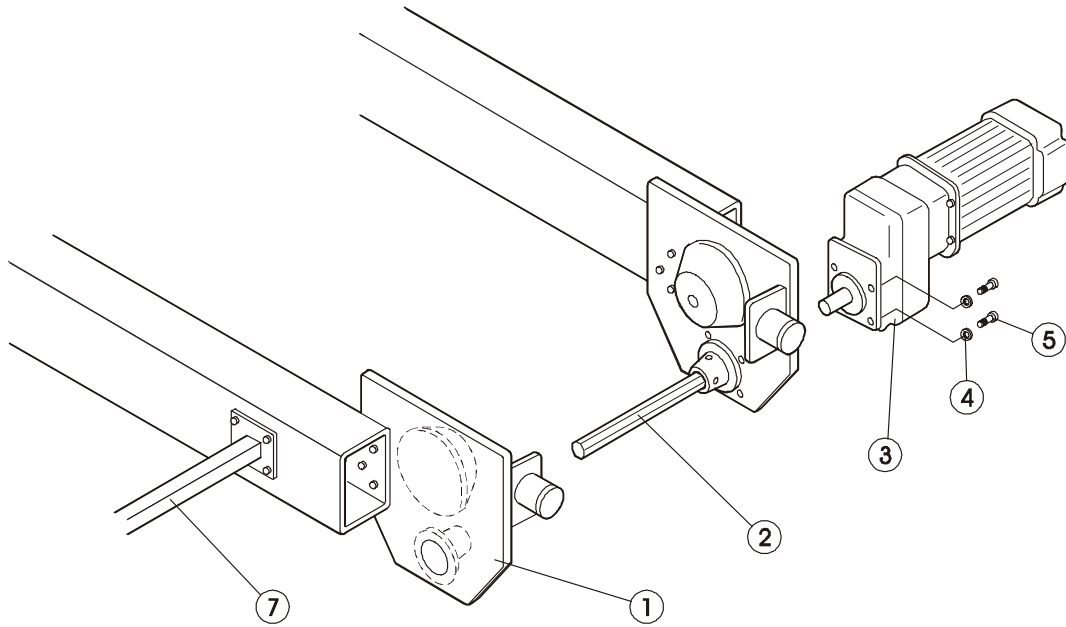

AIMCEN112A



Bridge Drive Assembly - UC End Truck

Parts List

- 1 End truck
- 2 Shaft
- 3 Bridge drive
- 4 Washer
- 5 Bolt
- 6 Pin
- 7 Crane tow arm
- 8 Cross shaft



Explanations for NOTES in the drawing

Drill 8mm hole for pin through pinion shoulder and cross shaft together. Use the existing pilot hole. Install split pin. Typical for both pinions



Crane Power Tow Arm Assembly

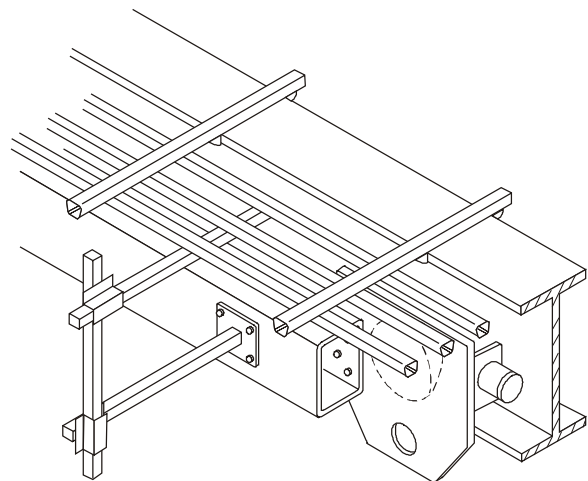
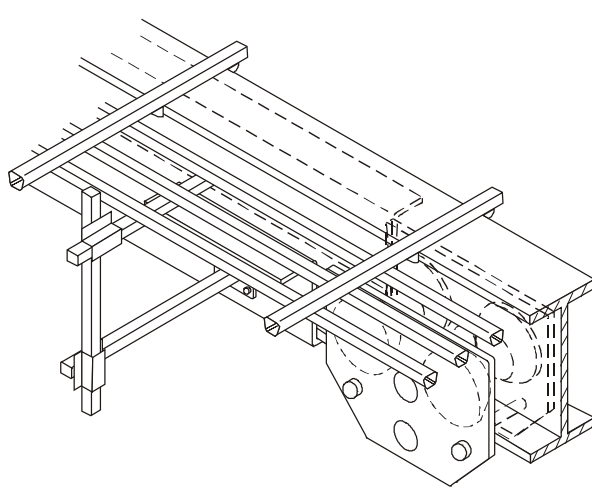
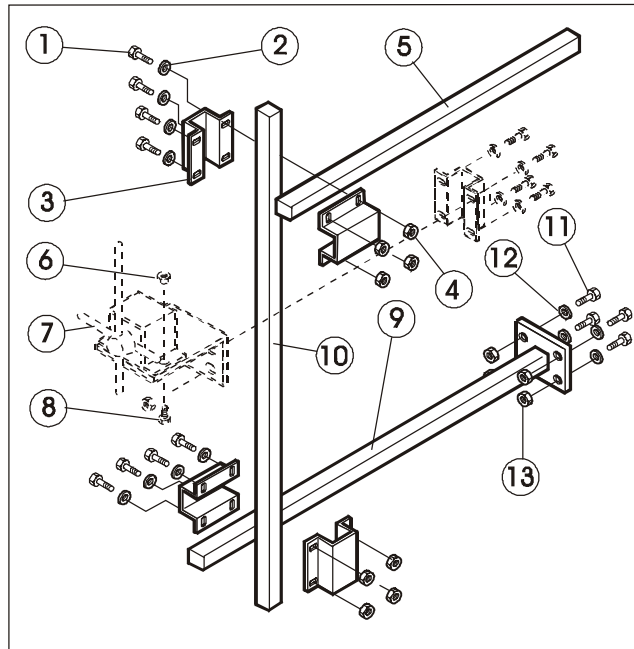

AIMCEN92A



Crane Power Tow Arm Assembly

Parts list

- 1 Bolt
- 2 Washer
- 3 Clamp
- 4 Tube
- 5 Nut
- 6 Bolt
- 7 Limit switch (optional)
- 8 Bolt
- 9 Tube
- 10 Tube
- 11 Bolt
- 12 Washer
- 13 Nut



Explanations for NOTES in the drawing

If necessary, cut off excess length of square tubes.

Hoist Tow Arm Assembly

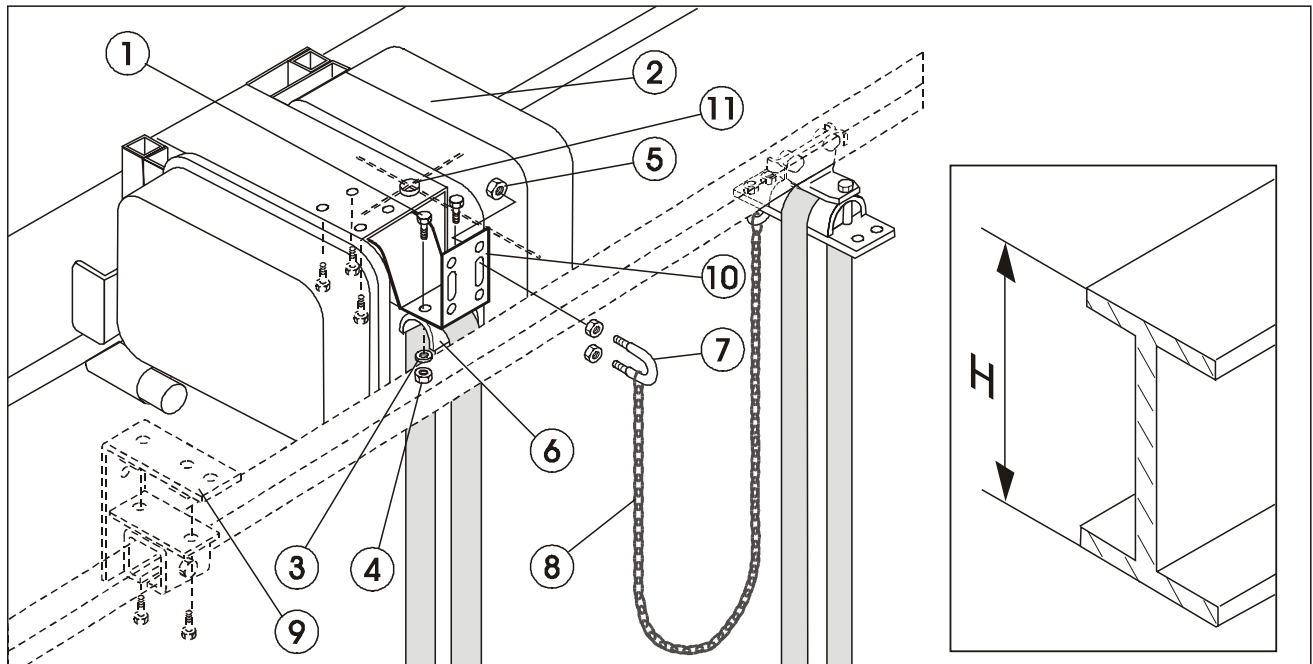

AIMCEN16B

$11 \frac{13}{16}'' [300 \text{ mm}] \leq H \leq 13 \frac{3}{8}'' [340 \text{ mm}]$. H is beam depth.

Parts list

- 1 Bolts
- 2 Hoist
- 3 Washer
- 4 Nuts
- 5 Nut
- 6 Plate
- 7 Loop
- 8 Chain
- 9 Limit switch end stop (optional)
- 10 Hoist tow arm
- 11 Limit switch (optional)

Hoist Tow Arm Assembly

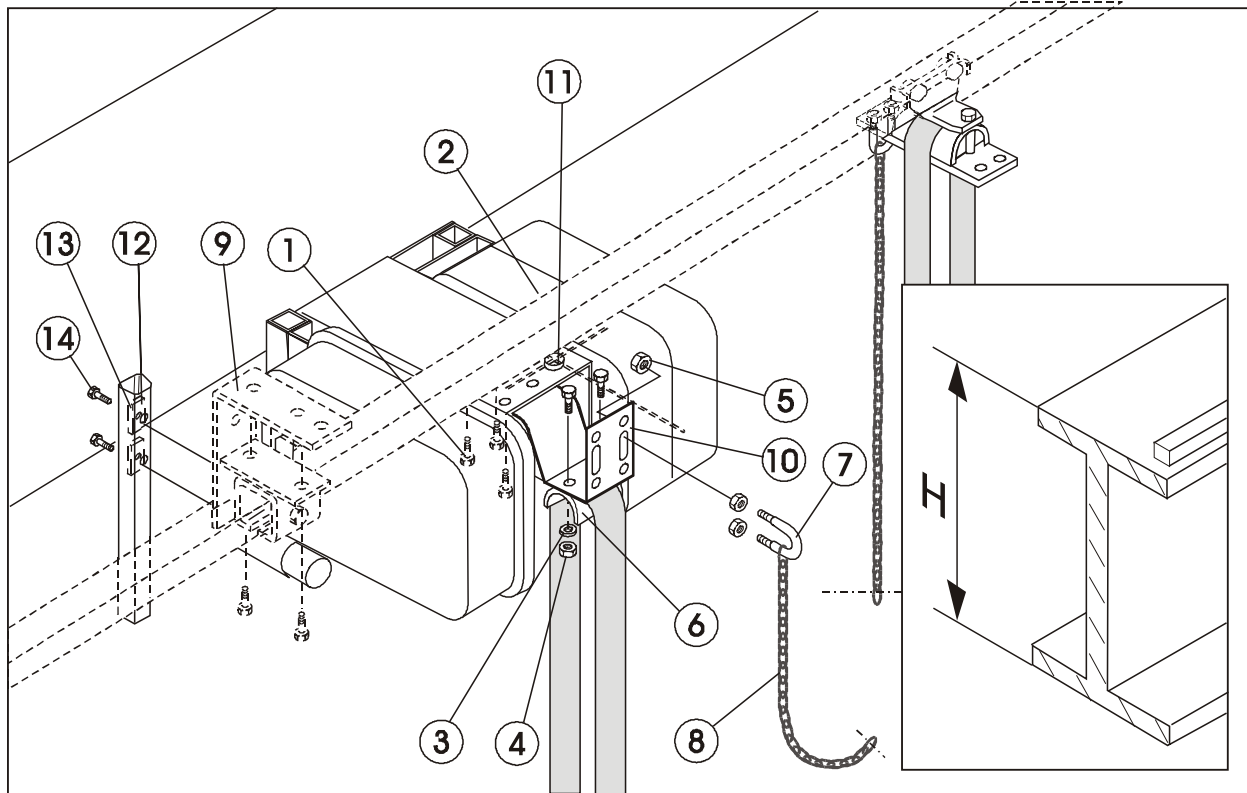

AIMCEN45A

$12 \frac{1}{2}'' [340 \text{ mm}] < H \leq 19 \frac{5}{8}'' [500 \text{ mm}]$. H is beam depth.

Parts list

- 1 Bolts
- 2 Hoist
- 3 Washer
- 4 Nuts
- 5 Nut
- 6 Plate
- 7 Loop
- 8 Chain
- 9 Limit switch end stop (optional)
- 10 Hoist tow arm
- 11 Limit switch (optional)
- 12 C-track
- 13 Square nut
- 14 Screw

Hoist Tow Arm Assembly

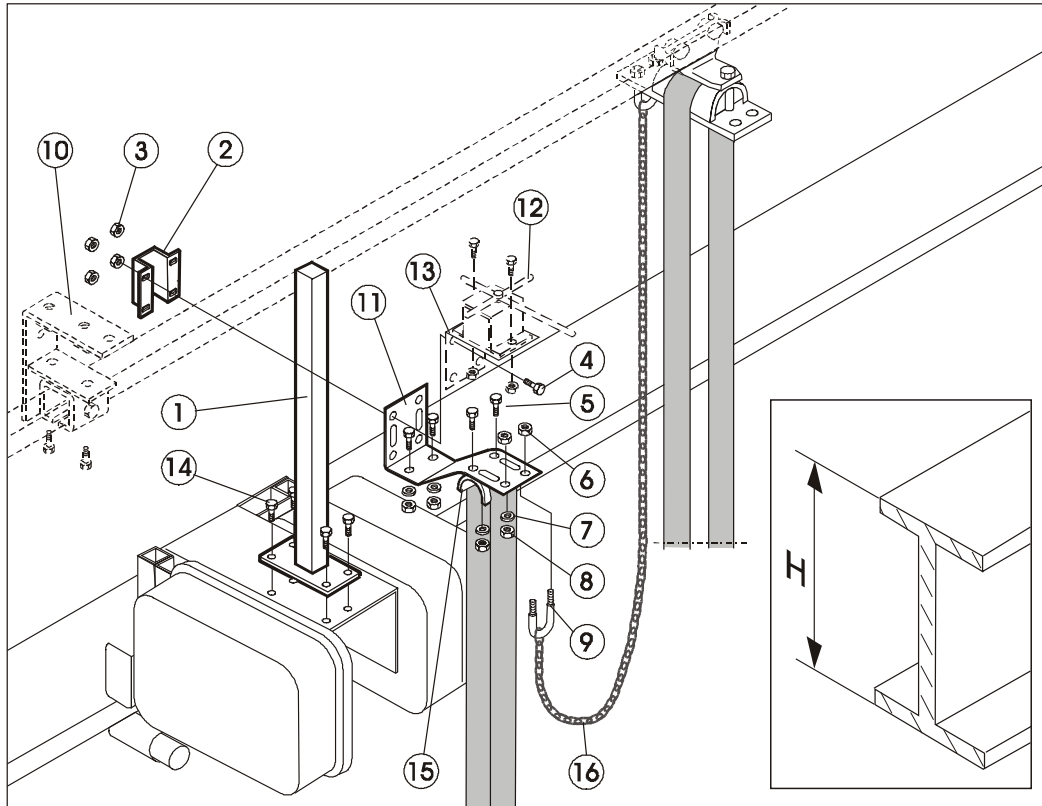

AIMCEN18B

H > 19 5/8" [500 mm], H is beam depth.

Parts list

- 1 Tube
- 2 Clamp
- 3 Nut
- 4 Bolt
- 5 Bolt
- 6 Nut
- 7 Washer
- 8 Nut
- 9 Loop
- 10 End stop for trolley limit switch (optional)
- 11 Tow arm
- 12 Limit switch (optional)
- 13 Plate (optional)
- 14 Bolt
- 15 Clamp
- 16 Chain

Bumper Stop Assembly ≤ 3 Ton [3200 Kg]

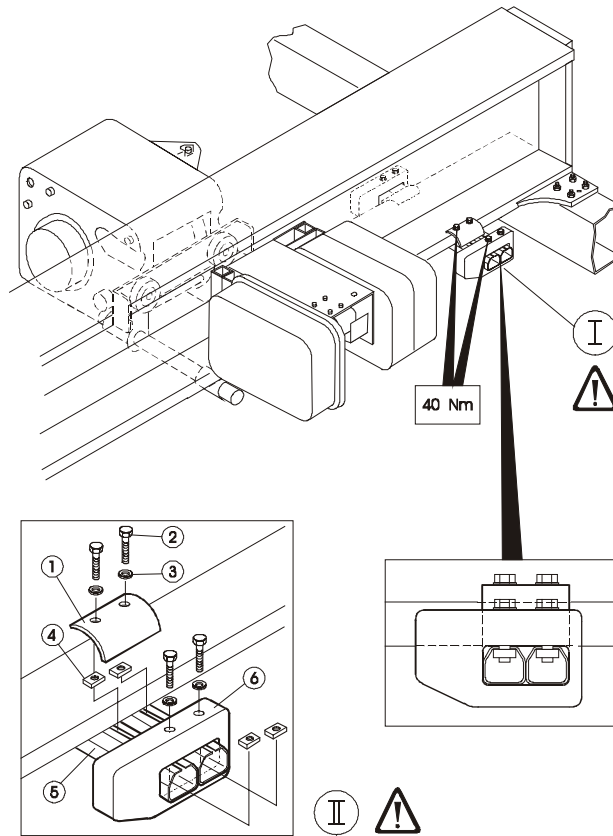

AIMCEN06A

Before installing trolley mounted hoists, the end stops must be installed for all trolleys mounted on open-end beams.

The end stops must be properly mounted so that the bumpers absorb any impact forces. Do not allow the trolley wheels to impact rail stops. In addition the end stops must be positioned on the beam so that the hoist unit does not impact the crane structure, end trucks and/or bridge drives.

Parts list

- 1 Clamps
- 2 Nut
- 3 Washer
- 4 Square nut
- 5 C-track
- 6 Bumper



Explanations for NOTES in the drawing

Make sure that the hoist bumper contacts center of end stop!

Make sure that the bumpers will stop the hoist on both ends of the crane, and not cable trolleys!

M12 Bolt Tightening Torque Specification 54 lb-ft.

Bumper Stop Assembly > 3 Ton [3200 Kg]

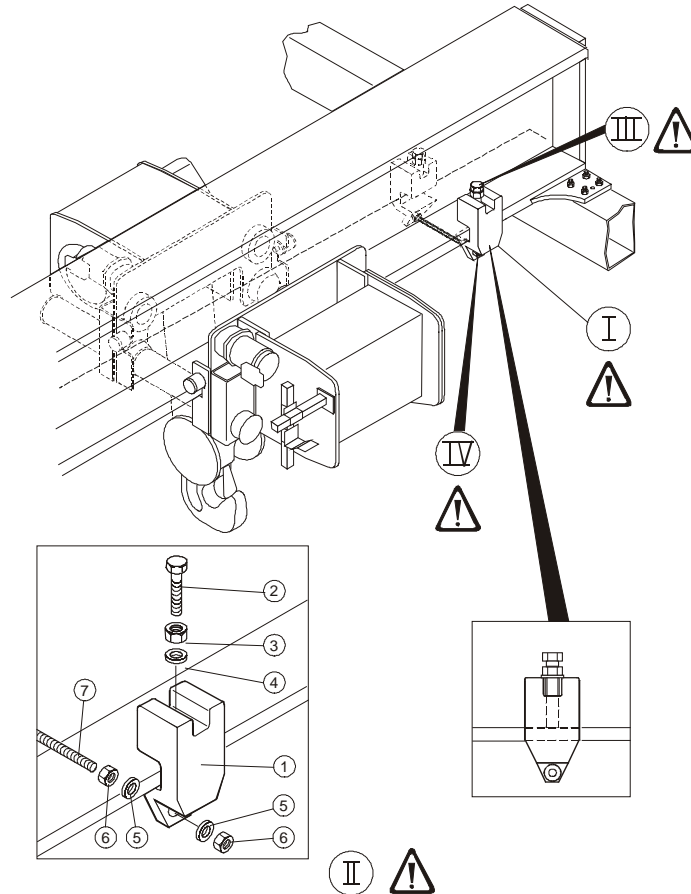

Before installing trolley mounted hoists, the end stops must be installed for all trolleys mounted on open-end beams.

The end stops must be properly mounted so that the bumpers absorb any impact forces. Do not allow the trolley wheels to impact rail stops. In addition the end stops must be positioned on the beam so that the hoist unit does not impact the crane structure, end trucks and/or bridge drives.

Parts List

- 1 End stop
- 2 Bolt
- 3 Nut
- 4 Washer
- 5 Washer
- 6 Nut
- 7 Threaded rod



Explanation for NOTES in the drawing

Mount and position trolley end stop assembly on the bridge girder.

Turn nuts (item 6) on each end of threaded rod until snug making sure the end stops are squared on the beam flange.

Tighten top bolts (item 2) on each end stop.

Tighten nuts (item 6) on each end of threaded rod.

Lock top bolt by tightening nut (item 3) against end stop.

Make sure that the trolley bumper contacts the center of end stop!



R&M Materials Handling, Inc
Springfield, Ohio USA
☎: 800 955-9967
web: www.rmhoist.com

Spacemaster SX Hoist
QX Crane Assembly Instructions
Single Girder Under Running
Revision 2

This page is intentionally left blank.



Bridge Panel Assembly

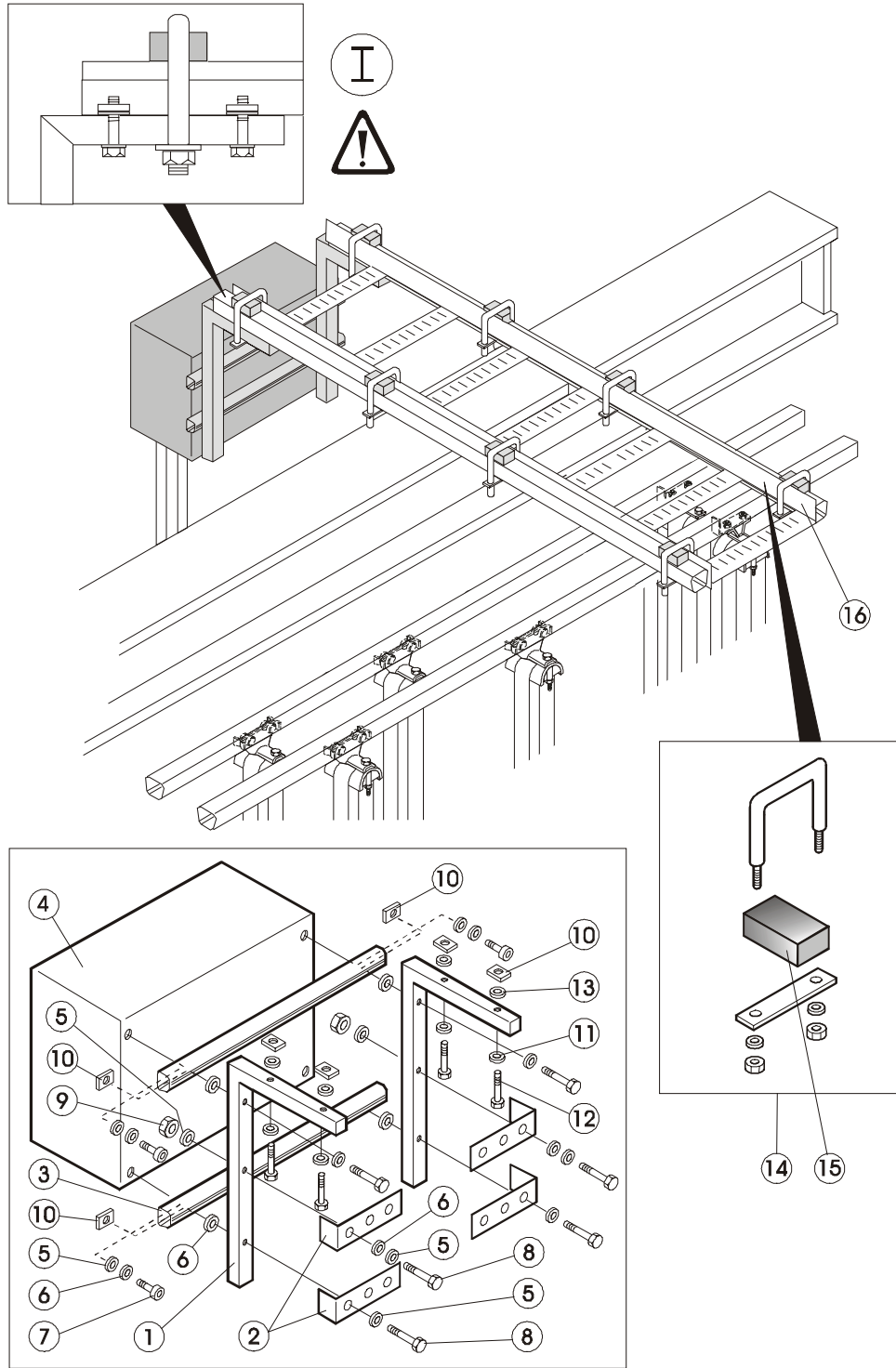

AIMCEN03C



Bridge Panel Assembly

Parts List

- 1 Support bracket
- 2 Plate
- 3 C-track
- 4 Bridge panel
- 5 Washer
- 6 Spring washer
- 7 Bolt
- 8 Bolt
- 9 Nut
- 10 Square nut
- 11 Washer
- 12 Bolt
- 13 Spring washer
- 14 Clamp
- 15 Rubber spacer
- 16 Ladder frame & C-rail



Explanation for NOTES in the drawing

Mount the support brackets to bridge panel before mounting bridge panel to crane.
Slide bridge panel assembly onto the C-rails of the ladder frame assembly.

The bridge panel ladder frame assembly does not support any festoon C-rails that run parallel to bridge girder.

Festoon Assembly

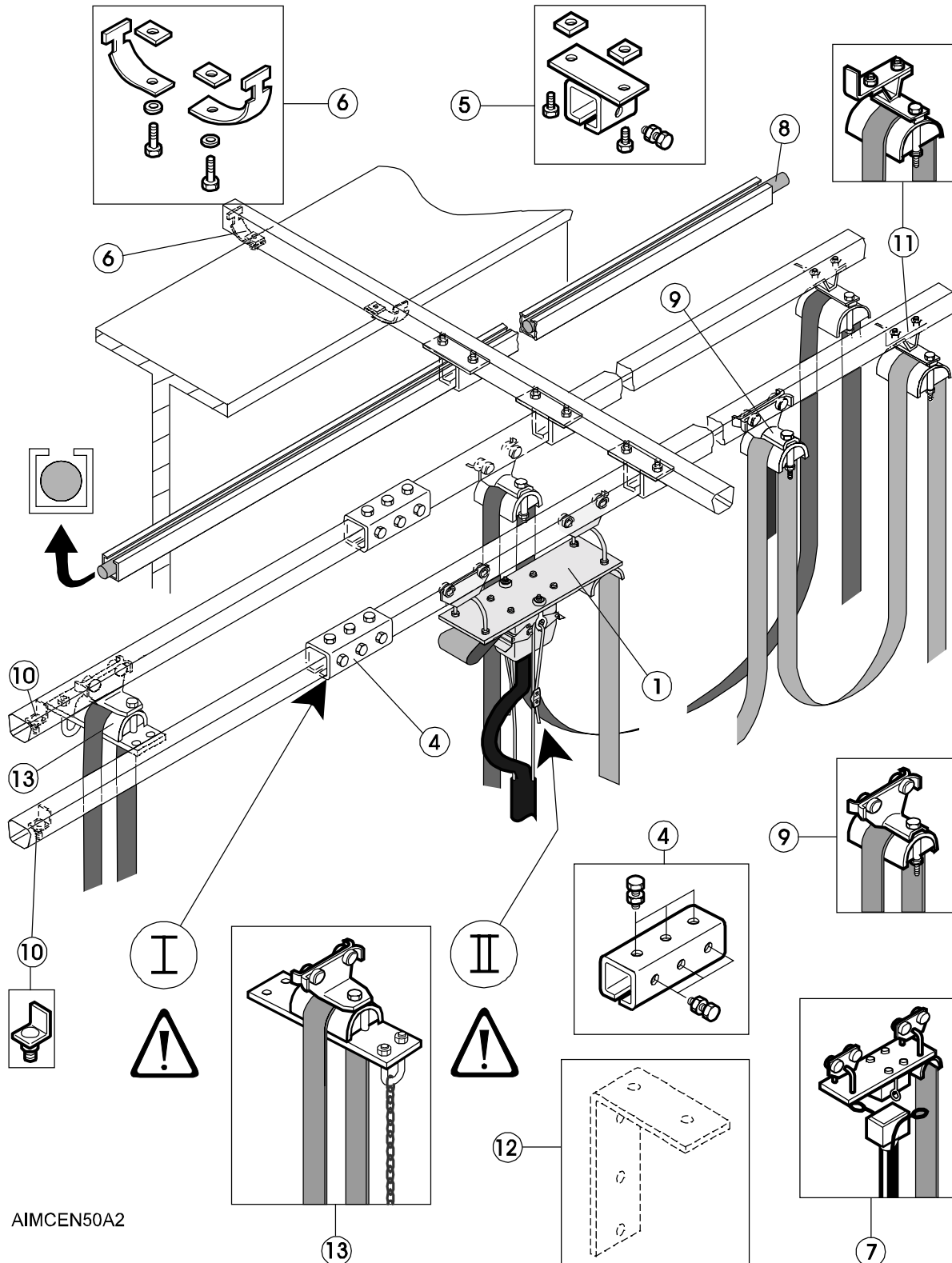



Festoon Assembly

Parts list

- 1 Pendant trolley
- 2 Support arm
- 3 C-track
- 4 Track coupler
- 5 Track support bracket
- 6 Beam clip
- 7 Control unit trolley
- 8 Cable for drive motor 2
- 9 Cable trolley
- 10 End stop
- 11 End clamp
- 12 Clip for cable attachment
- 13 Towing trolley



Explanation for NOTES in the drawing

Make sure that the C-rails are positioned into the track coupler so the rail joint is visible at the center holes of the coupler.

After properly positioning the C-rail into the track coupler, tighten each bolt on coupler. Lock each coupler bolt by tightening the nut against the coupler.

Make sure that the C-rail joint is smooth for tow trolley travel

Fasten each C-rail to each support arm by using the bracket. Tighten the bolts.

The bridge panel ladder frame assembly does not support any festoon C-rails that run parallel to bridge girder. See Bridge Panel Assembly.

Tighten the strain relief wires on both sides of the plug so that pendant cable is making a loop as shown. Tighten each wire clamp.



Plug Identification and Layout

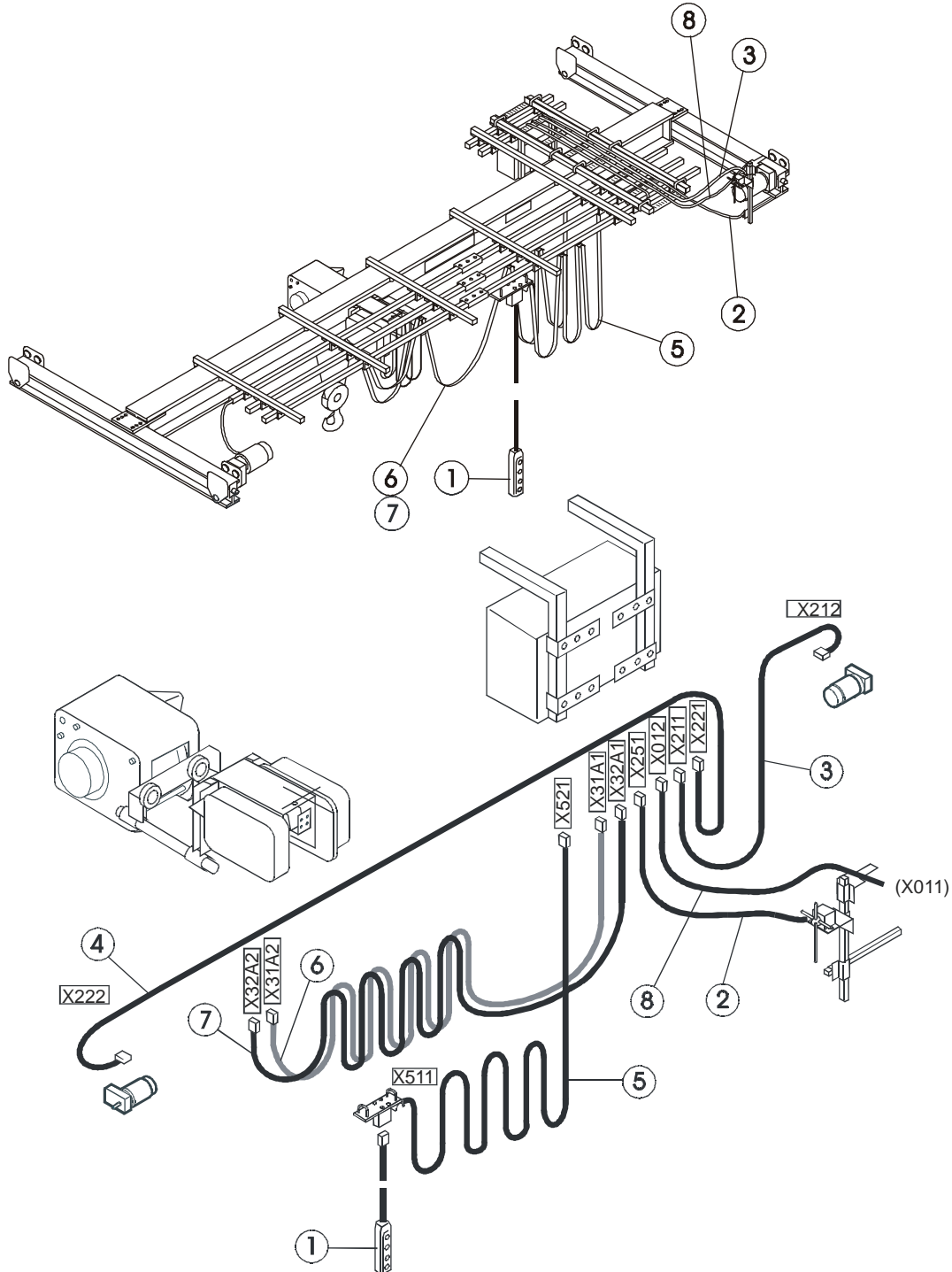

AIMCEN59A



Plug Identification and Layout

Parts List

- 1 Pendant
- 2 Cable for limit switch
- 3 Cable for bridge motor
- 4 Cable from bridge motor 2
- 5 Cable for pendant trolley
- 6 Cable for hoist power
- 7 Cable for hoist control
- 8 Cable for crane main power supply